

kanth



KV1R
Round Single Outlet Thermostatically Controlled Valve

INSTALLATION INSTRUCTIONS

Thank you for purchasing a Kanth Round Single Outlet Thermostatically Controlled Valve.
We are confident that this product, if installed correctly, will give you many years of trouble free showering.
In the event of any problems please contact us at support@kanth.london.

IT IS RECOMMENDED THAT THE INSTALLATION IS CARRIED OUT BY A QUALIFIED PLUMBER.

PLEASE READ THESE INSTRUCTIONS CAREFULLY BEFORE FITTING.

IMPORTANT

Please keep these instructions after installation, you will need the product reference information set out on the back page in order to validate and/or make a claim regarding the product guarantee.

DIMENSIONS

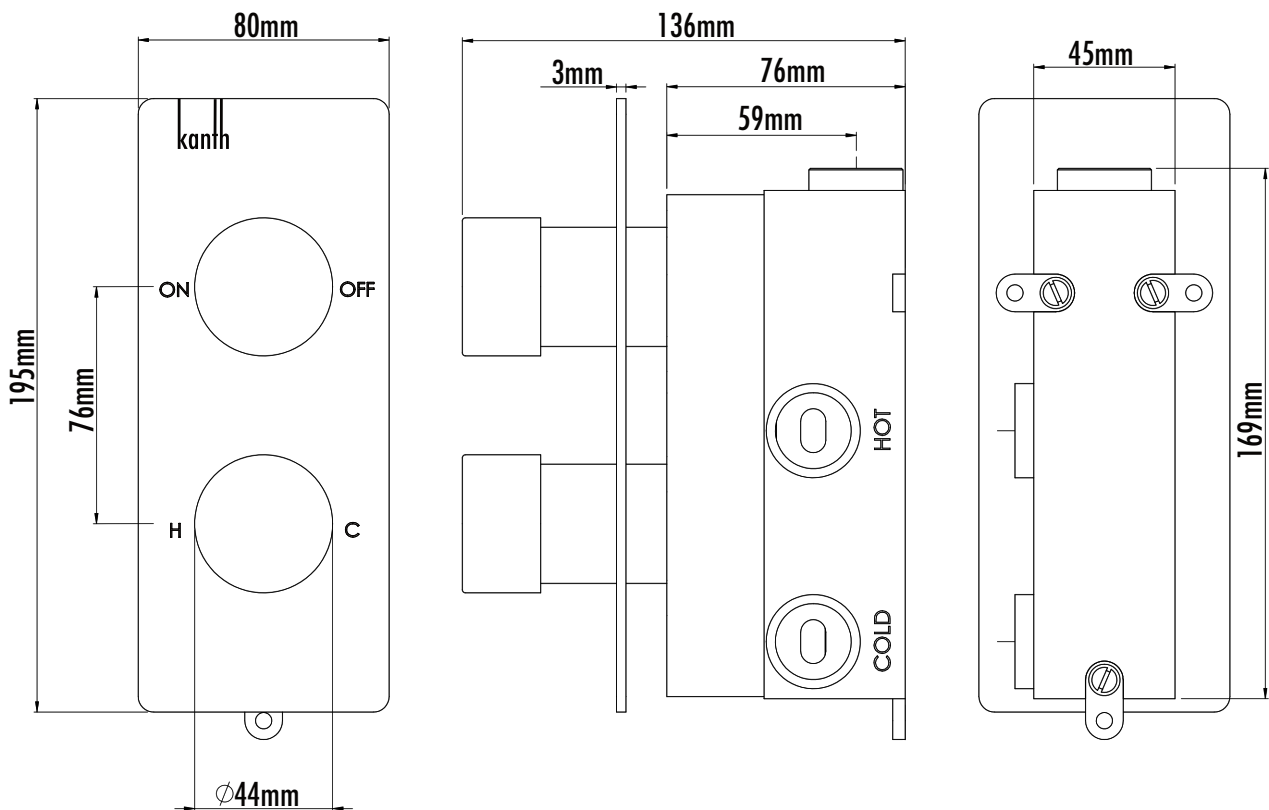

PLUMBING CONFIGURATION

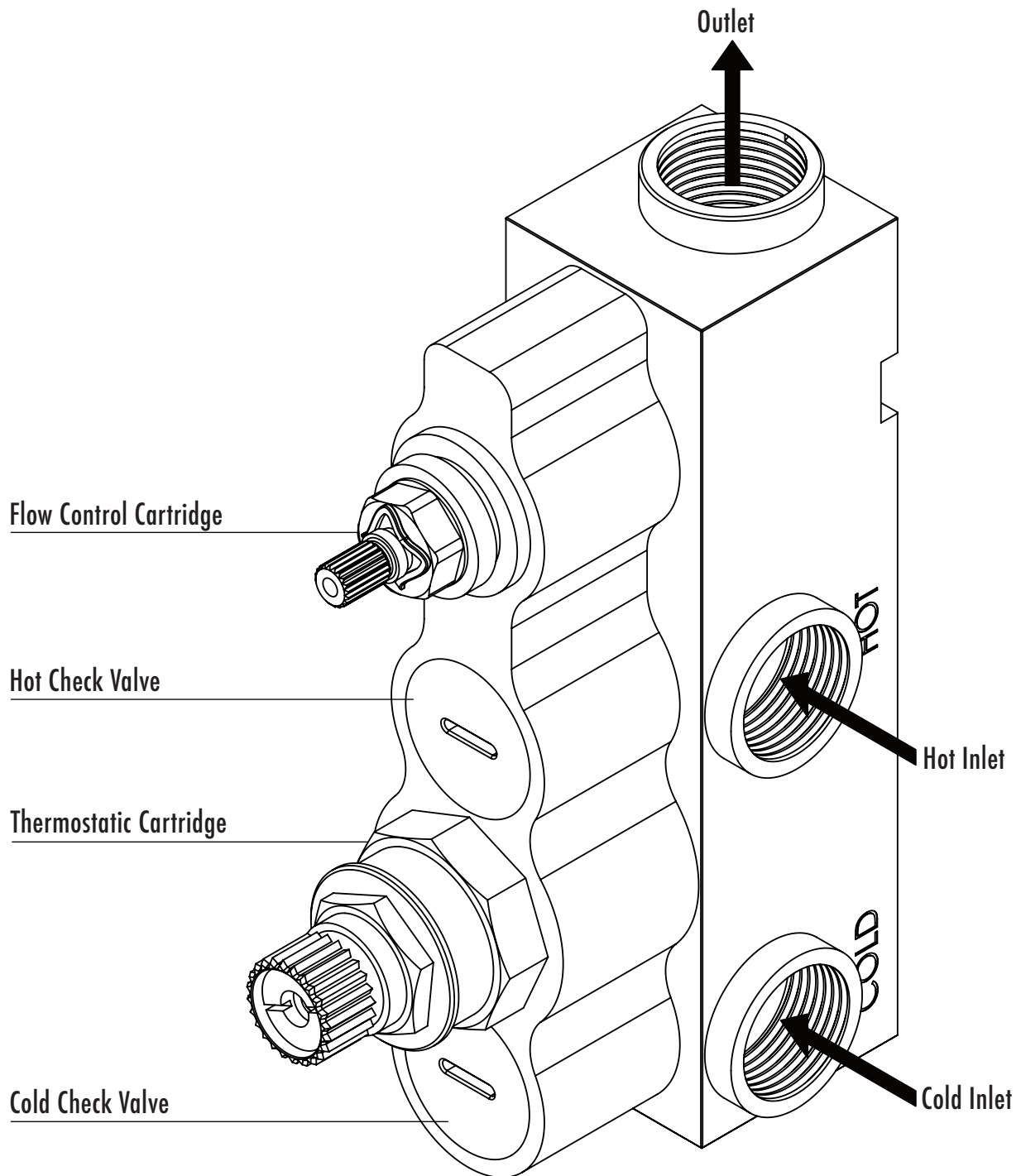

PLEASE NOTE: The valve must be installed with the plumbing on the right hand side as shown or this will result in the face plate being upside down - this cannot be reversed. It is essential to have access to the flow control cartridge, thermostatic cartridge and also the check valves to enable efficient servicing

KV1R INSTALLATION INSTRUCTIONS

1. Remove the $\frac{3}{4}$ " plastic insert plugs and discard
2. Screw the valve assembly to the wall using the fixing lugs. Care must be taken to ensure that the correct depth (see diagram) from the wall surface, including tiles, is maintained
3. Make the pipe work connections using a thread sealer. All inlets and outlets are tapped $\frac{3}{4}$ " BSP. ENSURE YOU DO NOT USE TAPERED THREADED ADAPTORS

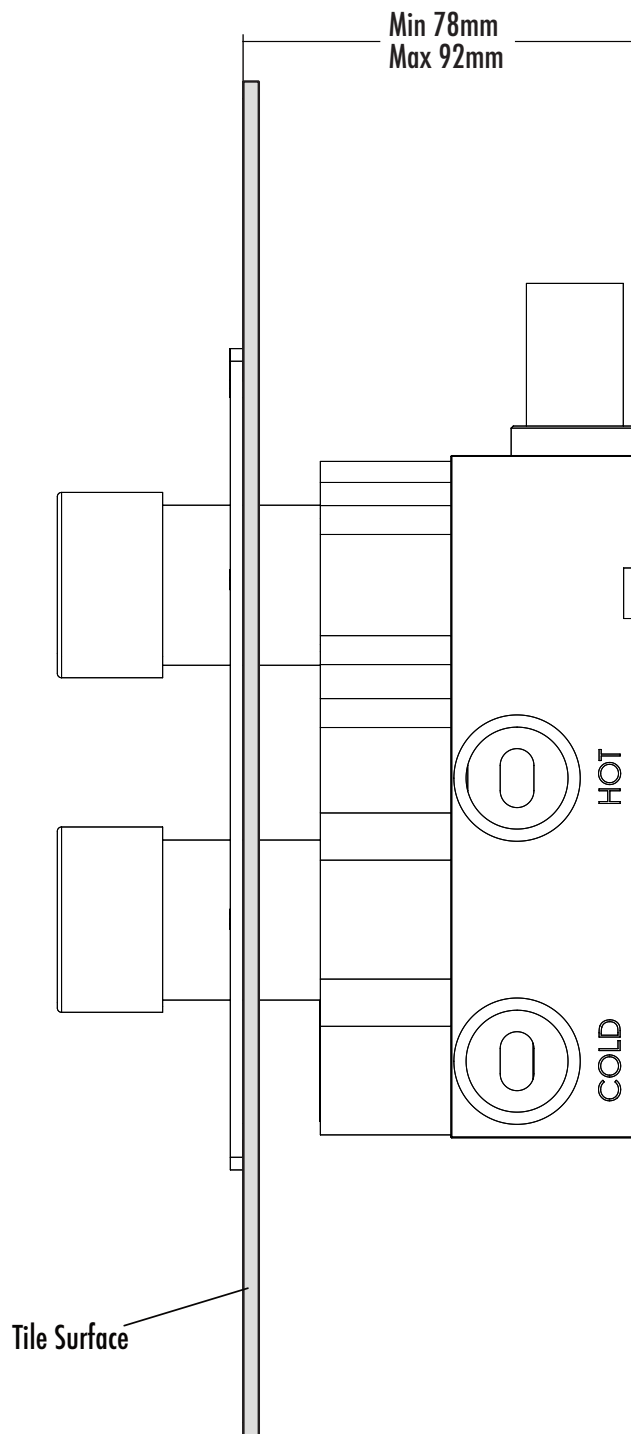

KV1R INSTALLATION INSTRUCTIONS

4. Turn on the water supplies to test the connections for water tightness
5. Turn off the water supply and flush out the system by removing the check valves and filters

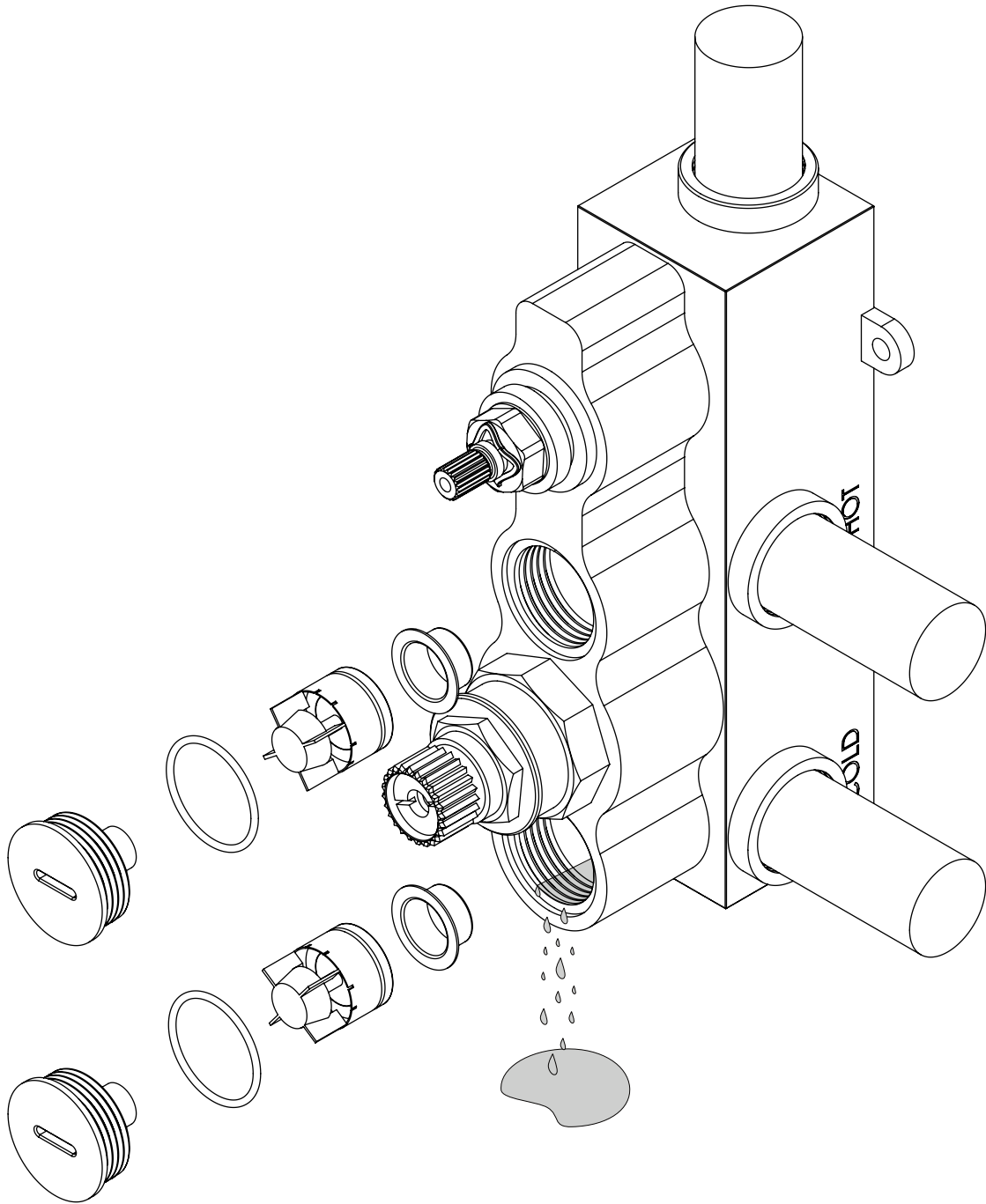

KV1R INSTALLATION INSTRUCTIONS

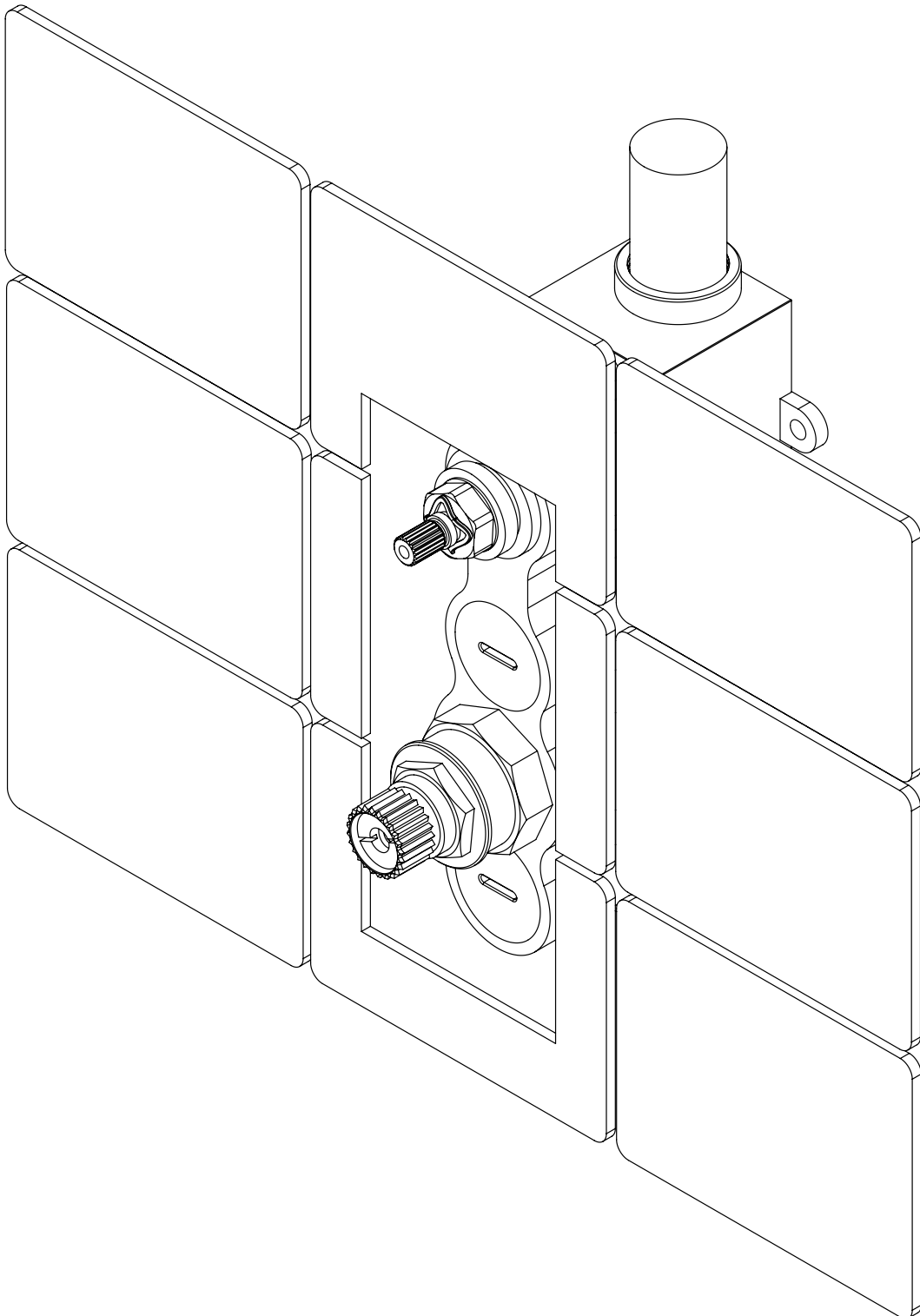

6. Replace the check valves and filters. Ensure that they are reinserted the correct way round and tighten the covers. Turn on the water to ensure that a water tight seal is made then turn off the water

7. Tile as shown following the guidelines on page 4 and ensure a hole of 55x156mm is cut to allow access to the cartridges and non return valves. The valve is now installed and is ready for the trim kit to be installed

KV1R INSTALLATION INSTRUCTIONS

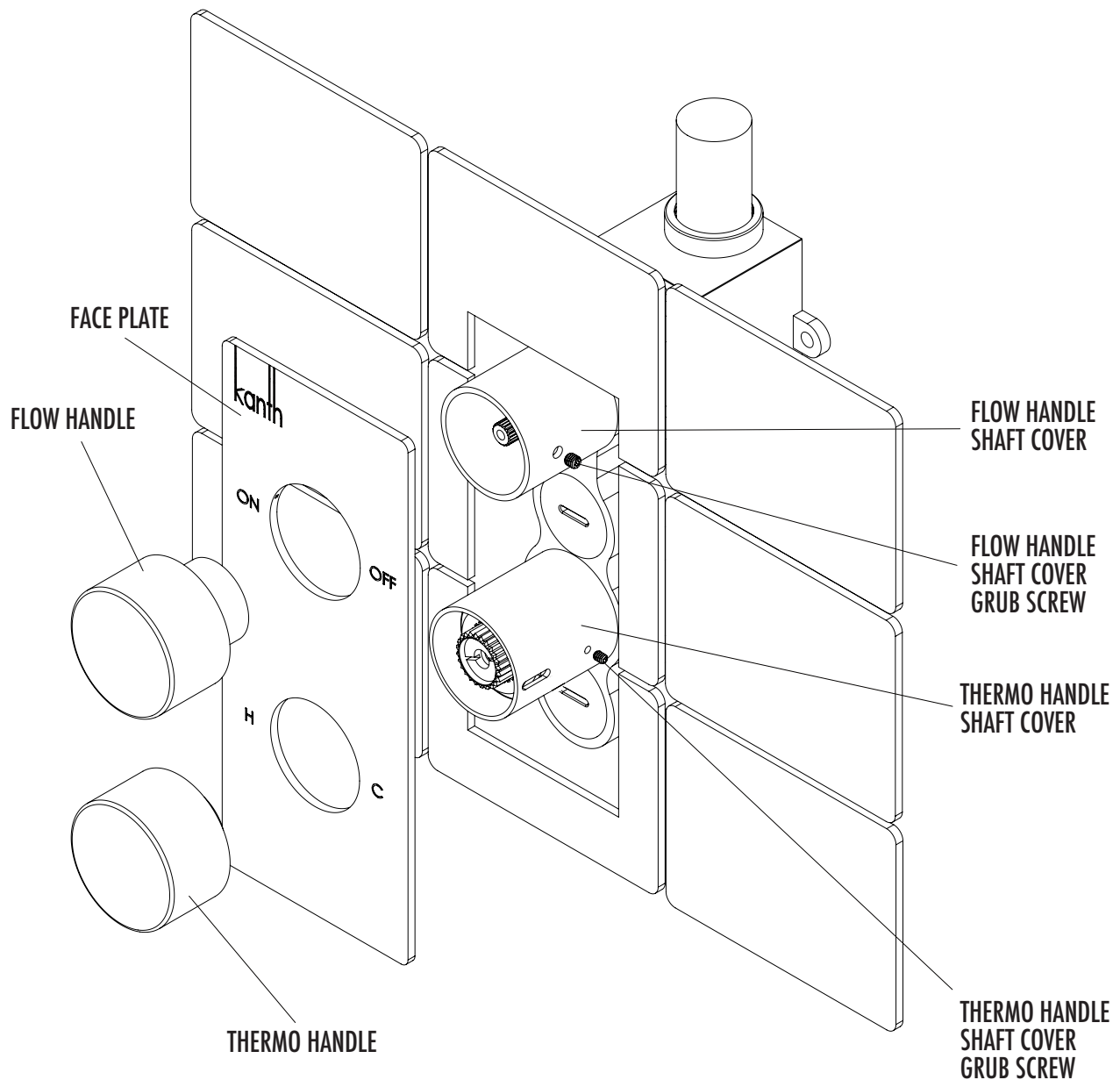

8. Push fit the shaft covers which will be held in place via the internal O-ring and ensure that they do not fall off whilst installing **(WE RECOMMEND FACING THE GRUB SCREW HOLES IN THE SHAFT COVERS DOWN AFTER INSTALLATION TO CONCEAL THEM, THEY ARE SHOWN ON THE SIDE IN THIS DIAGRAM FOR INSTRUCTIONAL PURPOSES)**

9. Place the face plate over the shafts and seal to the wall using a sealant of your choice

10. The handles can now be attached using the grub screws. Place the handle on the spline so that it is level when in the off position. Turn the handle to line up the grub screw on the handle and tighten with a 2mm Allen key. Place the thermostat handle on the spline and line up the grub screw with the access hole and tighten the screw

11. Turn on the water and ensure that all connections to the valve and the outlets are watertight

12. The valve is now ready for use

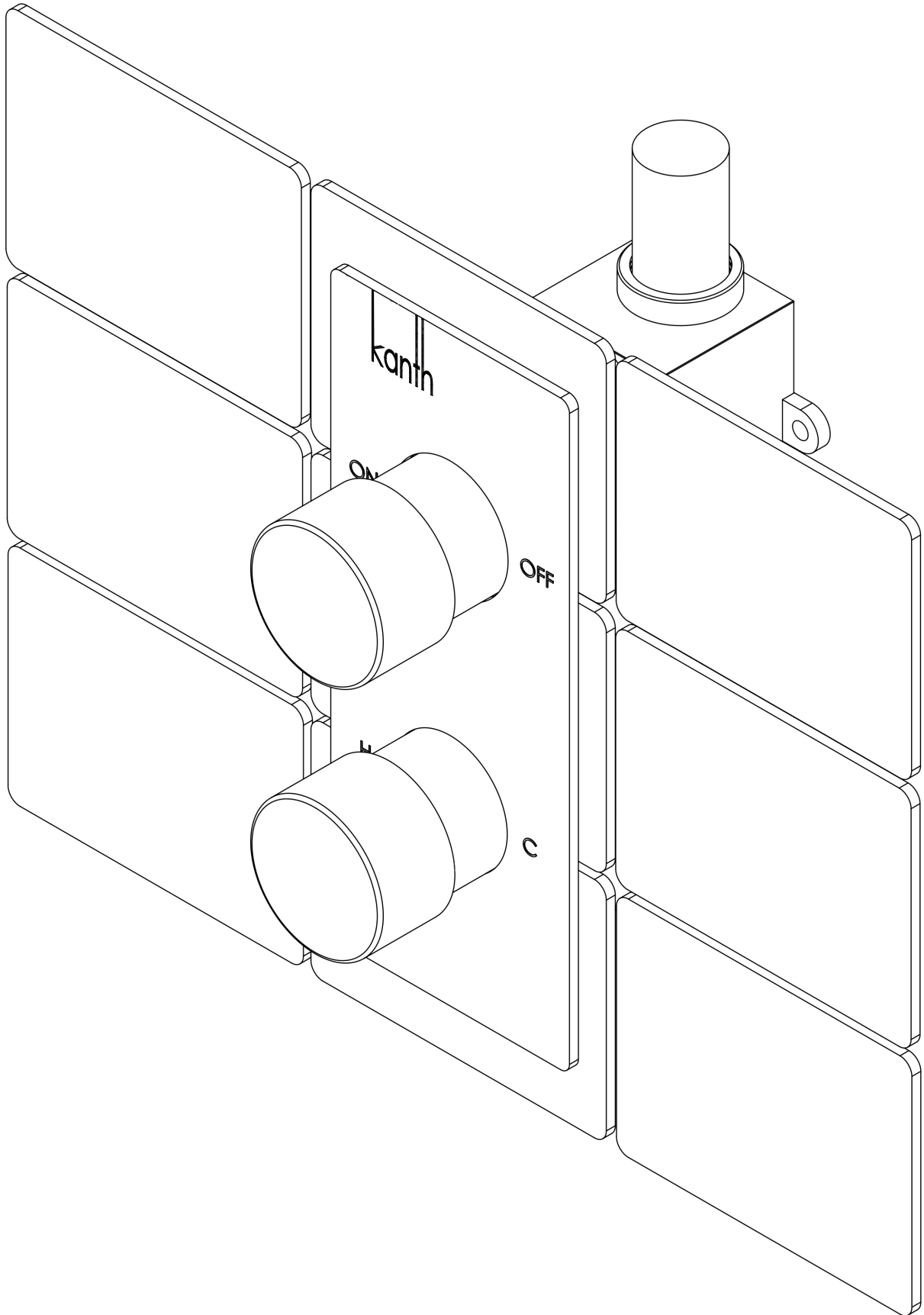

KV1R SETTING THE MAXIMUM TEMPERATURE

1. The top handle controls the water flow. ¼ turn anticlockwise turns the water fully on

2. The thermostatic cartridge is controlled by the second handle. Turn anticlockwise for hotter water

IMPORTANT:

You will need to set the maximum temperature that you would like the water to run at

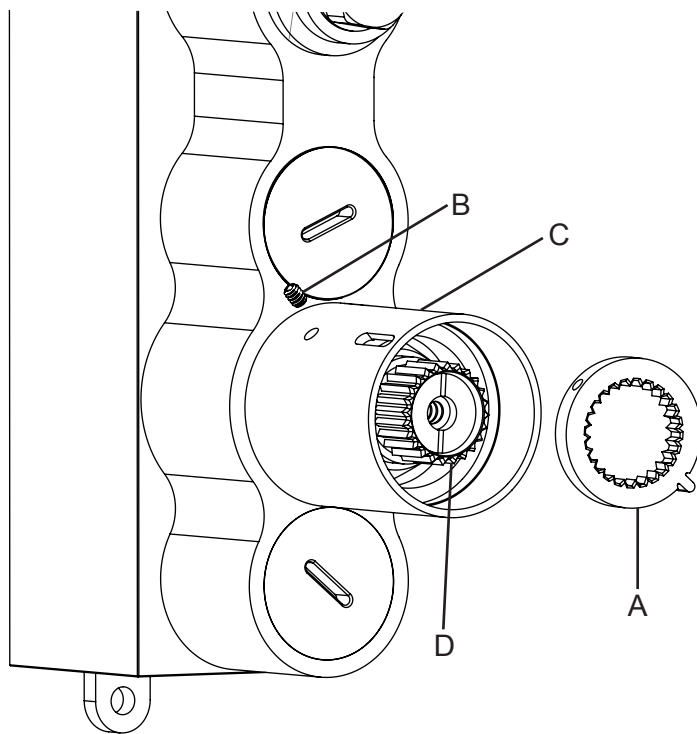
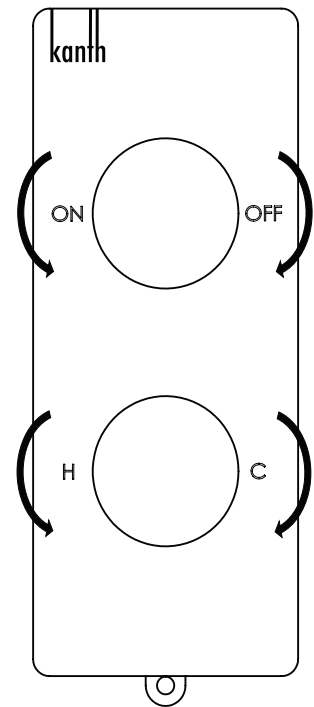

3. To set the maximum temperature you must remove the temperature limiter ring 'A'. To do this you must first remove the thermostat handle

Next remove the limiter ring 'A' (If you have difficulty removing the limiter ring you can undo the grub screw 'B' which releases the outer casing 'C', this can be used to tap the limiter ring off the thermostat spindle. Reposition the outer casing 'C' and re-tighten grub screw 'B' before proceeding)

4. Next rotate the thermostat spindle 'D' until you have reached the maximum temperature desired. Then reposition the limiter ring 'A' on the thermostat spindle 'D' so it rests against the projecting stud on the inside of the casing 'C'

Finally replace the thermostat handle

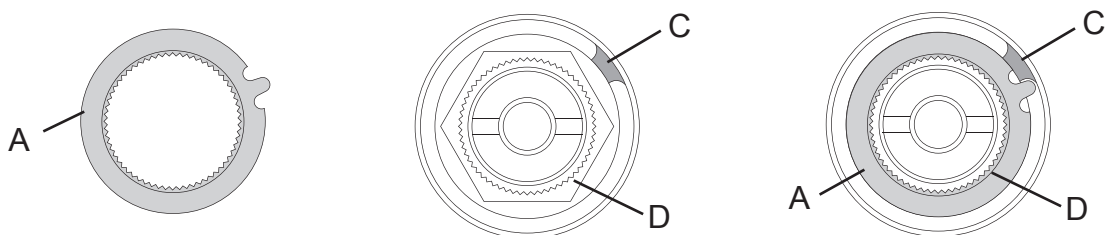

KV1R EXPLODED VIEW

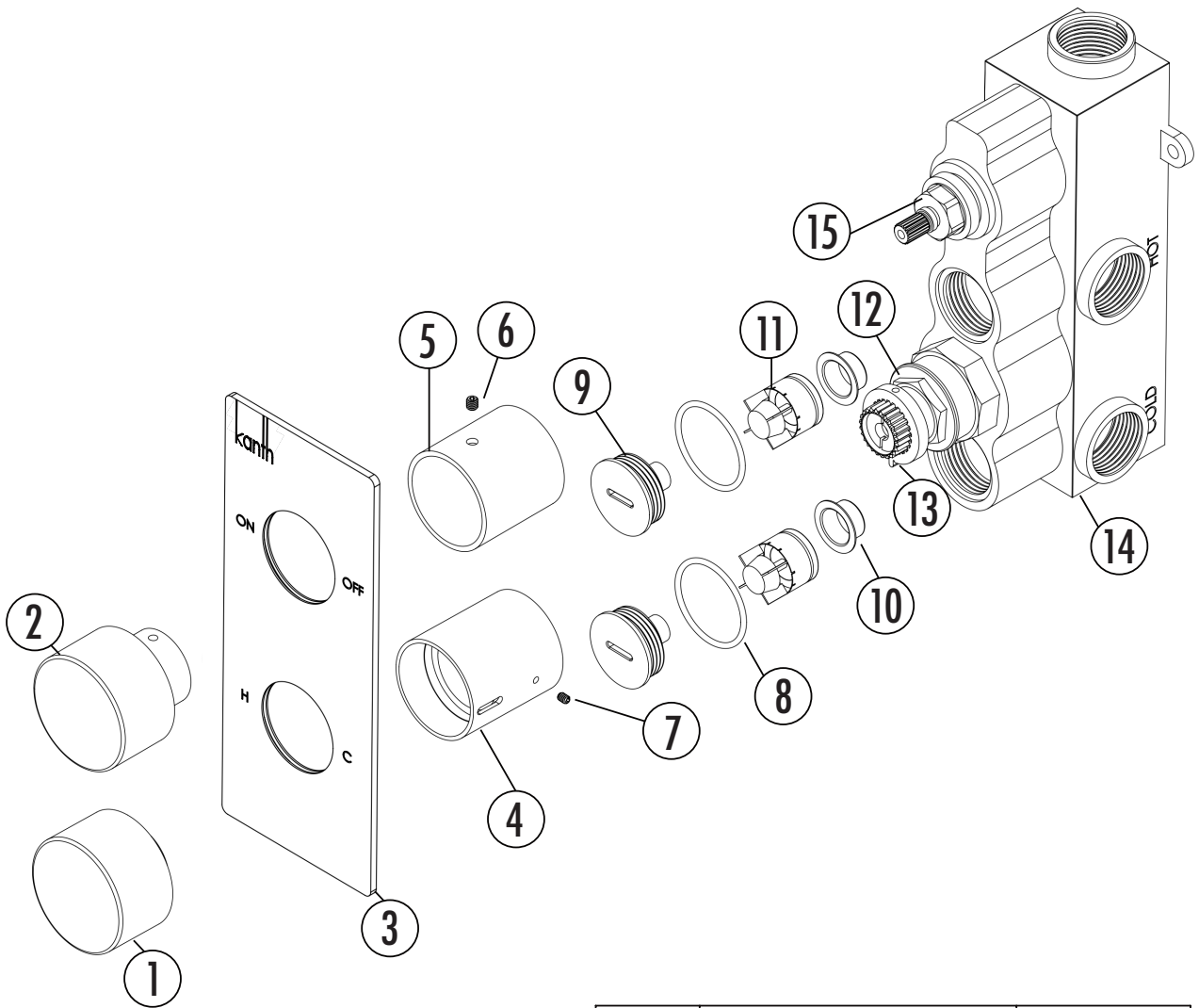

ITEM NO	DESCRIPTION	CODE
1	ROUND THERMO HANDLE	CBHN.THR.KVR
2	ROUND FLOW HANDLE	CBHN.FLW.KVR
3	2 HOLE FACE PLATE	CBCP.VK1.KVU
4	THERMO SHAFT COVER	CBSC.THR.KVU
5	FLOW SHAFT COVER	CBSC.FLW.KVU
6	FLOW SHAFT GRUB SCREW	COFX.GRB.002
7	THERMO SHAFT GRUB SCREW	COFX.GRB.001
8	NRV CAP O RING	COSL.ORG.015
9	NRV CAP PLUG	CBFG.PLG.002
10	FILTER	COFG.FTG.004
11	NON RETURN CHECK VALVE	COFG.FTG.007
12	THERMOSTATIC CARTRIDGE	COFG.CTG.005
13	LIMITER RING	CBFG.TSC.KVC
14	KV1 SHOWER VALVE	CBVB.VB1.KVC
15	FLOW CARTRIDGE	COFG.CTG.001

KANTH GUARANTEE

Concealed Valve Body & Trim Set – 25 Year Guarantee

We guarantee the brass concealed shower valve body and trim set including; all handles, shaft covers and face plates, against defects in workmanship and raw material for a period of 25 years. Within the guarantee period we will resolve defects by repairing or replacing defect components free of charge.

As our products are designed to last longer than you may be staying in your house, we will allow all customers who register their product with us to transfer the guarantee to the new owners of their property.

Consumable Components – 12.½ Year Guarantee

Your product will be affected by general wear and tear through daily use. As with any products there will be a requirement to replace consumable parts periodically dependent on frequency of use and how the product is maintained. All consumable components are guaranteed for a period of 12.½ years or half the lifetime of the product and we will keep a full stock of all parts for the life of the product. Consumable Components include;

Flow Control Cartridges	Thermostatic Cartridge	Seals
Check Valves	Filters	O rings

Consumable Components Extended Lifetime Guarantee

In addition to the standard 12.½ year guarantee provided on the consumable components, we offer an extended guarantee which will cover your product for the full 25-year lifetime, at a one-off low cost. This extended guarantee can be purchased when registering your product or at a later date. For further information on how to extend the guarantee please visit www.kanth.london.

MAINTENANCE AND CLEANING

The controls and face plate should be cleaned frequently by wiping with a damp soft cloth and polished with a dry duster. Cleaners containing alcohol, acid or corrosive materials should not be used.

Thermostatic cartridge, we recommend that once per week the handle controlling the temperature should be turned fully left and fully right before placing back in original condition to help extend life of your product.

Do not use abrasive cleaners, detergents or polishes, this will cause harm to the finish of your product and void the guarantee.

Visit www.kanth.london for more guidance on maintenance & cleaning.

REFRESH SCHEME

To ensure the longevity and sustainability of our products we offer our Refresh Scheme. It is designed to support our customers for the duration of our products' lifetime, maintaining the performance and look of the product while also allowing adaptations to account for new tastes. Not only this but it brings down the cost of ownership, making our products both luxury and outstanding value.

Our Refresh Scheme offers two simple options:

The first is **renew** – our product is designed to last for at least 25 years, but we know many homeowners look to refresh their bathroom every five to six years. So, when you replace your tiles and fittings you simply leave the valve body installed where it is and return the external trim set (handles, shaft covers and face plate) to our UK factory for renewal. We'll either refresh the current finish or plate the set in an alternative finish which matches your new bathroom.

Secondly, if you decide to **replace** your Kanth product with a different style, then we can exchange your original product and offset the cost against your new choice. And don't worry, your returned product won't go to waste – we will renew it and put it back into our stock.

We are constantly improving and simplifying our processes, for full up to date details on our Refresh Scheme please visit www.kanth.london.

Replacement Parts

As part of our sustainability policy we reserve the right to replace any faulty component with a new or renewed replacement, on the provision that there will be no likelihood detriment to the function of the supplied component. Any replacement parts are guaranteed until the expiry of the original a guarantee

Guide to a Full and Long Valve Life

Customers often look to replace components long before they require replacing. This is sometimes due to misdiagnosis of fault, speed of repair, or incorrect installation. At Kanth we always recommend in the first instance reading our troubleshooting guide at www.kanth.london.

FINISHES

We use the best materials, processes and skilled labour to ensure the highest standard of finishes to our products. Depending on the finish, products may vary in coloration and effect. We endeavour to minimise and ensure assembled items match as far as possible. Each finish is subject to its own guarantee period due to the nature of the finish, these include;

Polished Chrome	5 years
Polished/Brushed Nickel	2 years
Lacquered Special Finishes*	2 years
Unlacquered Polished/Brushed Brass**	No Guarantee

Special Finishes – Our special finishes are created by hand, by skilled metal finishers. We apply unique processes which alter the appearance of the raw material surface through a combination of polishing, brushing and chemicals. Each piece will be unique and vary slightly in appearance adding to the beauty of each product.

*Lacquered Finishes - As standard we supply any Special Finish with a lacquered coating. We have spent many years researching and developing our lacquer coating to provide a hard durable surface, which combines our products aesthetic beauty with longevity. However, like all surfaces this lacquer can be degraded through the use of harsh chemicals and abrasives. If your products are treated well and maintained as per the instructions you will have many years of unblemished use.

**Unlacquered Finishes – all of our products are manufactured from solid brass ingots, and as such, when left unprotected they will age, tarnish and change in appearance over time – this is often referred to as a living finish. Aged brass can be wonderful in appearance and offer a very unique and individual finish. We have no control over living finish products and as such can offer no guarantee to their appearance after supply.

For a full list our finishes and their guarantee periods visit www.kanth.london.

Please note; Any claim for a faulty finish will only be successful if all products have been maintained and cleaned as per the guidance stated, failure to do so will void this guarantee period.

LIMITATIONS AND EXCLUSIONS

This guarantee does not cover damage or defects arising as a result of;

Non-domestic use	Misuse	Careless handling
Incorrect installation	Wilful damage	Modifications
Accident	Use of abrasive or chemical cleaners	Limescale**

** If problems result from limescale we will be happy to replace products forwarded to us and a fee will be charged for this service.

Our liability is limited to the repair or replacement of those products supplied and registered only. This guarantee is only valid for products installed within the United Kingdom and the Republic of Ireland.



TO MAKE A CLAIM

To make a claim you must either have:

1. Registered your product with us or be at the address registered on our records or;
2. Have dated proof of purchase of the product from one of our registered suppliers, contractors',
3. Acknowledgement of the date on installation and be the original purchaser.

CONTACT US

For support, information or spare parts please email customer services at;

Email: support@kanth.london

TO REGISTER YOUR PRODUCT

Please Note: It is important to register your product in order to receive your full guarantee.

Please complete the enclosed registration card, or register your product online at www.kanth.london

Product Serial No.